

SQUARE ROOT EXTRACTOR

SHN-SQT



Converting DC input signal into an isolated square root output signal.

- Various 2-wire transmitters application.
- Square root extractor application(4~20mA).
- Contains linearizer circuit.
- 1 or 2 outputs are available from 1 input.
- Contains overvoltage protection circuit.
- Transformer isolation type.

MODEL & SUFFIX CODE SELECTION

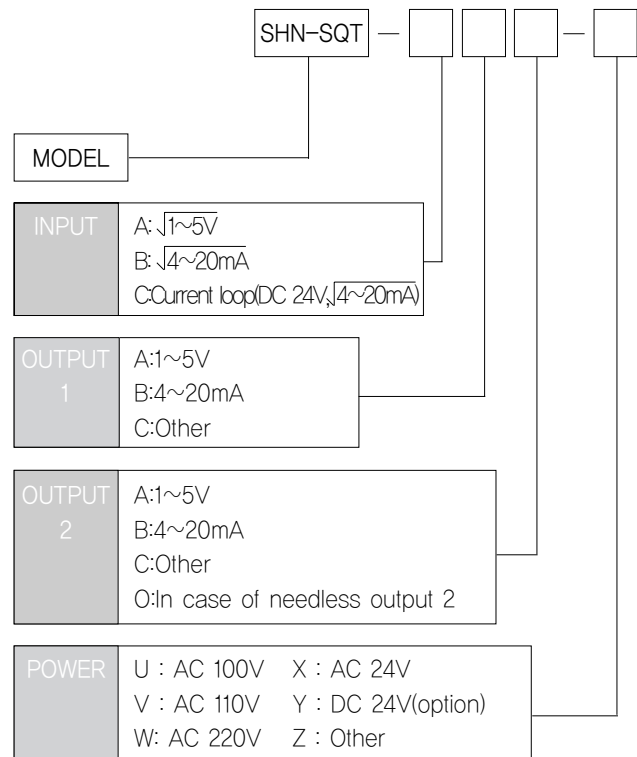

GENERAL SPECIFICATIONS

Isolation/Type	Input to output to power/Transformer isolation type		
Power Supply	AC rating $\pm 10\%$, approx. 3.5VA DC rating $\pm 10\%$, (ripple 10%)100mA		
Accuracy	$\pm 0.3\%$ (Max)		
Temp Coefficient	$\pm 0.02\%$ / $^{\circ}C$ ($\pm 0.008\%$ / $^{\circ}F$)		
Linearity	$\pm 0.03\%$ F.S		
Insulation Resistance	Greater than 100M Ω with DC 500V		
Dielectric Strength	Input - Power	AC 2500V	1 minute
	Input - Output		
	Output 1 - Output 2		
	GND - Power		
Front Adjustments	Zero and Span $\pm 10\%$		
Overrange Output	approx. -10% ~ 110% at DC 1~5V		
Response Time	≤ 0.5 sec (0~90%)		
Operating Temperature/Humidity	-20~60 $^{\circ}C$ / 90%(N.C)		
Storage Temperature/Humidity	-20~80 $^{\circ}C$ / 95%(N.C)		
Dimensions	8 pin: W50xH85xD122(mm)		
	11 pin: W50xH85xD133(mm)		
Case Material	ABS Resin (black)		
Weight	about 400g		
Mounting	Wall & Rail mounting		

INPUT & OUTPUT SPECIFICATIONS

Input Impedance

Input	Impedance
$\sqrt{4 \sim 20\text{mA}}$	250Ω
$\sqrt{1 \sim 5\text{V}}$	1MΩ (Min)

Output Load Resistance

Output	1 Point	2 Point		Remark
	Output	Output-1	Output-2	
4 ~ 20mA	700Ω	600Ω	350Ω	(Max)
1 ~ 5V	5kΩ	5kΩ	5kΩ	(Min)

BLOCK DIAGRAM

1 Point Output

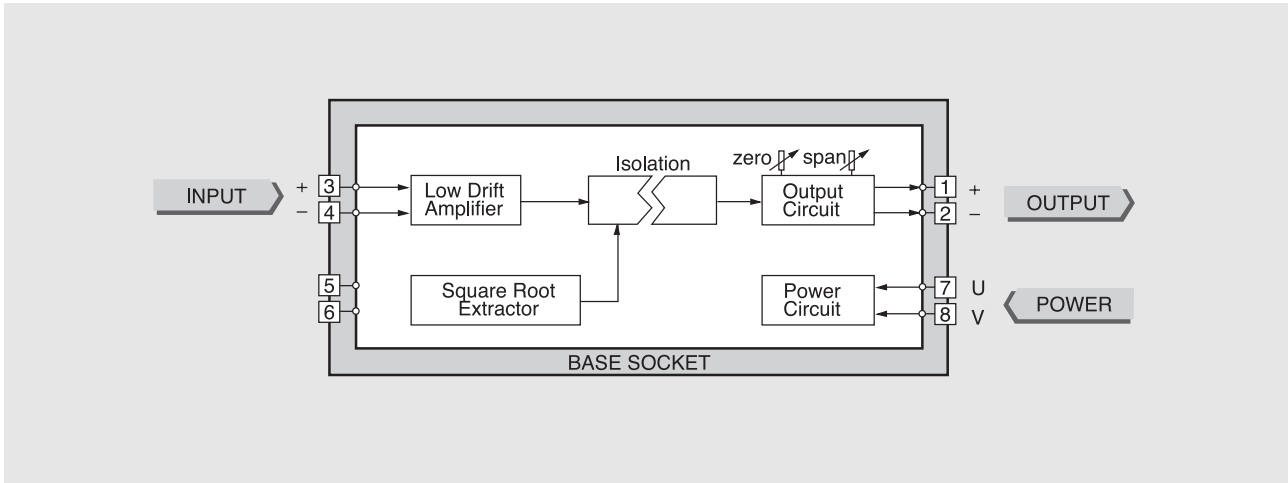

2 Point Output

